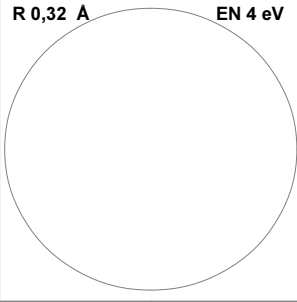
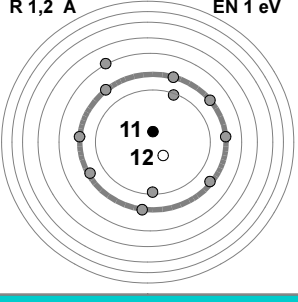
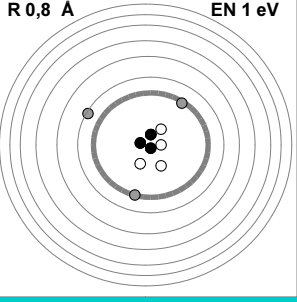

Etapa 1

Equip 6

**9 Bu**  
**Buda**  
 No Metall. Gas.  
 R 0,32 Å EN 4 eV  
  
 1s2 2s2 2p5  
**19**

**11 D**  
**Dali**  
 Metall. Sòlid.  
 R 1,2 Å EN 1 eV  
  
 1s2 2s2 2p6 3s1  
**23**

**3 P**  
**Picass**  
 Metall. Sòlid.  
 R 0,8 Å EN 1 eV  
  
**7**

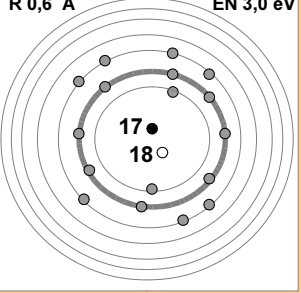
**17 La**  
**LaoTse**  
 No Metall. Gas.  
 R 0,6 Å EN 3,0 eV  
  
 1s2 2s2 2p6 3s2 3p5  
**39**

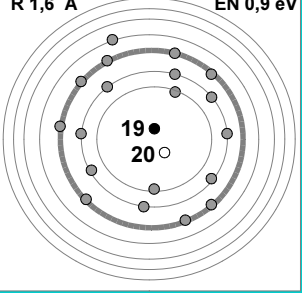
**19 R**  
**Renoir**  
 Metall. Sòlid.  
 R 1,6 Å EN 0,9 eV  
  
 1s2 2s2 2p6 3s2 3p6 4s1  
**39**

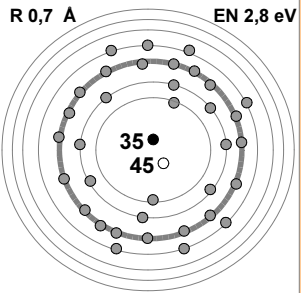
**Co**  
**Confuci**  
 No Metall. Líquid.  
 R 0,7 Å EN 2,8 eV  
  
 1s2 2s2 2p6 3s2 3p6 4s2 3d10 4p5  
**80**

Etapa 2

Equip 6

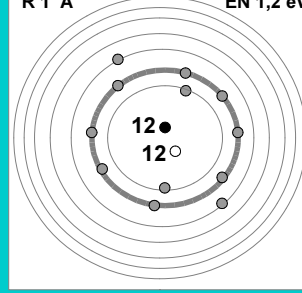
**12 C**  
**Chopin**  
 Metall. Sòlid.  
 R 1 Å EN 1,2 eV  
  
 1s2 2s2 2p6 3s2  
**12**

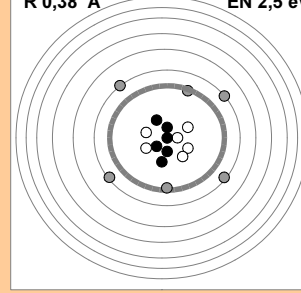
**6 Es**  
**Espru**  
 Metall. Sòlid.  
 R 0,38 Å EN 2,5 eV  
  
 1s2 2s2 2p2  
**12**

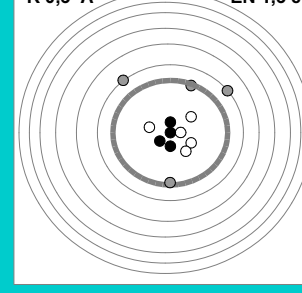
**4 Mo**  
**Mozart**  
 Metall. Sòlid.  
 R 0,5 Å EN 1,5 eV  
  
**9**

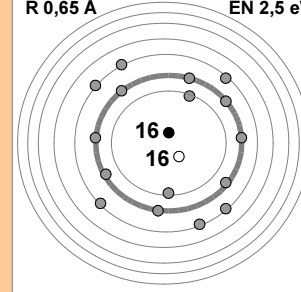
**16 PI**  
**Plato**  
 No Metall. Sòlid.  
 R 0,65 Å EN 2,5 eV  
  
 1s2 2s2 2p6 3s2 3p4  
**32**

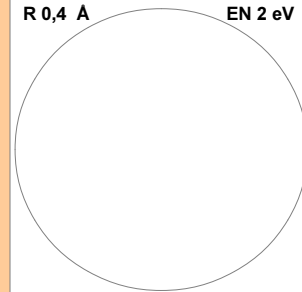
**5 Ma**  
**Machad**  
 Metall. Sòlid.  
 R 0,4 Å EN 2 eV  
  
 1s2 2s2 2p1  
**11**

Etapa 3

Equip 6

<p><b>34 S</b></p> <p><b>Socrat</b></p> <p>No Metall. Sòlid.</p> <p>R 0,76 Å EN 2,4 eV</p> <p>1s2 2s2 2p6 3s2 3p6 4s2 3d10 4p4</p> <p><b>79</b></p>	<p><b>8 Ar</b></p> <p><b>Aristot</b></p> <p>Metall. Gas.</p> <p>R 0,34 Å EN 3,5 eV</p> <p>1s2 2s2 2p4</p> <p><b>16</b></p>	<p><b>10 En</b></p> <p><b>Einstein</b></p> <p>No Metall. Gas.</p> <p>R 0,3 Å EN -- eV</p> <p>1s2 2s2 2p6</p> <p><b>20</b></p>
---	--	---

<p><b>7 S</b></p> <p><b>Stalin</b></p> <p>Metall. Gas.</p> <p>R 0,36 Å EN 3 eV</p> <p>1s2 2s2 2p6 3s2 3p6 4s2</p> <p><b>14</b></p>	<p><b>20 B</b></p> <p><b>Betobén</b></p> <p>Metall. Sòlid.</p> <p>R 1,3 Å EN 1 eV</p> <p>1s2 2s2 2p6 3s2 3p6 4s2</p> <p><b>4</b></p>	<p><b>2 N</b></p> <p><b>Niuton</b></p> <p>No Metall. Gas.</p> <p>R 0,4 Å EN -- eV</p> <p>1s2</p> <p><b>4</b></p>
--	--	--

Etapa 4

Equip 6

<p><b>1 V</b></p> <p><b>Vangog</b></p> <p>Metall. Gas.</p> <p>R 0,5 Å EN 1,2 eV</p> <p>1s1</p> <p><b>1</b></p>	<p><b>22 Ma</b></p> <p><b>Maiqueliasen</b></p> <p>Metall. Sòlid.</p> <p>R 0,9 Å EN 1,4 eV</p> <p>1s2 2s2 2p6 3s2 3p6 4s2 3d2</p> <p><b>48</b></p>	
<p><b>45 V</b></p> <p><b>Vanmorris</b></p> <p>Metall. Sòlid.</p> <p>R 1 Å EN 1,3 eV</p> <p>1s2 2s2 2p6 3s2 3p6 4s2 3d1</p> <p><b>45</b></p>	<p><b>45 Pa</b></p> <p><b>Pattismit</b></p> <p>Metall. Sòlid.</p> <p>R 0,81 Å EN 1,9 eV</p> <p>1s2 2s2 2p6 3s2 3p6 4s2 3d10 4p6 5s2 4d7</p> <p><b>103</b></p>	<p><b>6 Ps</b></p> <p><b>Papasseit</b></p> <p>Metall. Sòlid.</p> <p>R 0,38 Å EN 2,5 eV</p> <p>1s2 2s2 2p2</p> <p><b>14</b></p>

Etapa 5

Equip 6

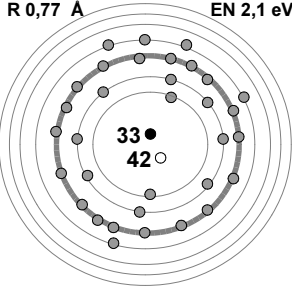
**33** **Ca**  
**Carlomag**  
 No Metall. Sòlid.  
 R 0,77 Å EN 2,1 eV  
  
 1s2 2s2 2p6 3s2 3p6 4s2 3d10 4p3  
**75**

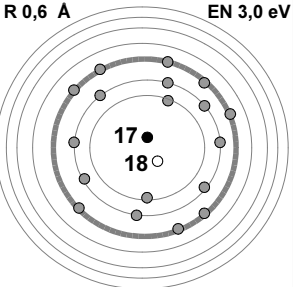
**17** **L<sup>1-</sup>**  
**LaoTse**  
 No Metall. Gas.  
 R 0,6 Å EN 3,0 eV  
  
 1s2 2s2 2p6 3s2 3p6  
**35**

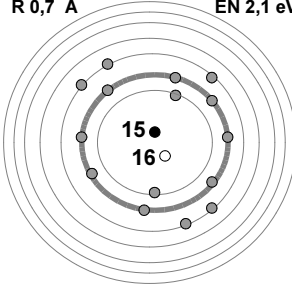
**15** **J**  
**Julicesa**  
 No Metall. Sòlid.  
 R 0,7 Å EN 2,1 eV  
  
 1s2 2s2 2p6 3s2 3p6  
**31**

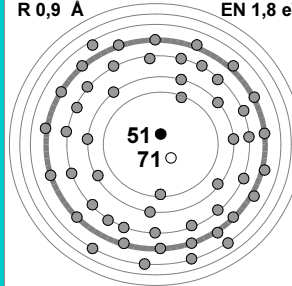
**51** **Ge**  
**Gengiskan**  
 Metall. Sòlid.  
 R 0,9 Å EN 1,8 eV  
  
 1s2 2s2 2p6 3s2 3p6 4s2 3d10 4p6 5s2 4d10 5p3  
**122**

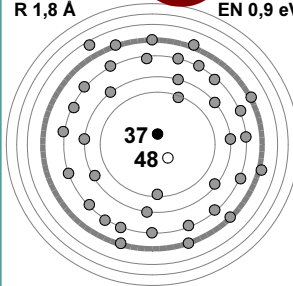
**M**  
**Monet**  
 Metall. Sòlid.  
 R 1,8 Å EN 0,9 eV  
  
 1s2 2s2 2p6 3s2 3p6 4s2 3d10 4p6 5s1  
**85**

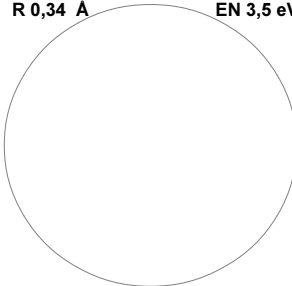
**8** **Ar<sup>2-</sup>**  
**Aristot**  
 Metall. Gas.  
 R 0,34 Å EN 3,5 eV  
  
 1s2 2s2 2p6  
**16**

Etapa 6

Equip 6

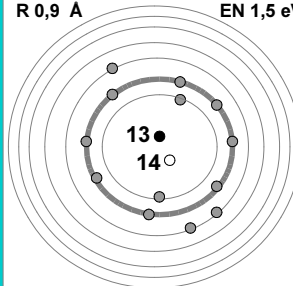
**13** **Lo**  
**Lorc**  
 Metall. Sòlid.  
 R 0,9 Å EN 1,5 eV  
  
 1s2 2s2 2p6  
**27**

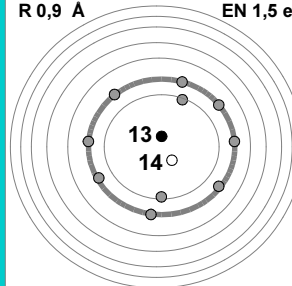
**13** **Lo<sup>3+</sup>**  
**Lorc**  
 Metall. Sòlid.  
 R 0,9 Å EN 1,5 eV  
  
 1s2 2s2 2p6  
**27**

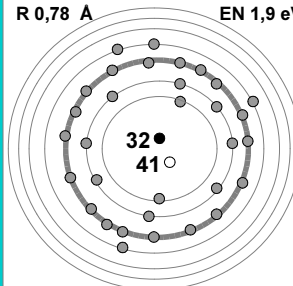
**32** **Ve**  
**Verdaguel**  
 Metall. Sòlid.  
 R 0,78 Å EN 1,9 eV  
  
 1s2 2s2 2p6 3s2 3p6 4s2 3d10 4p2  
**73**

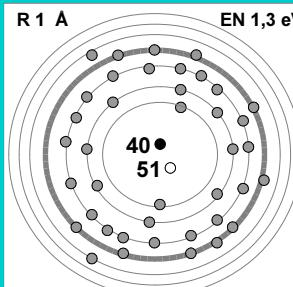
**40** **Bi**  
**Bibiquin**  
 Metall. Sòlid.  
 R 1 Å EN 1,3 eV  
  
 1s2 2s2 2p6 3s2 3p6 4s2 3d10 4p6 5s2 4d2  
**91**

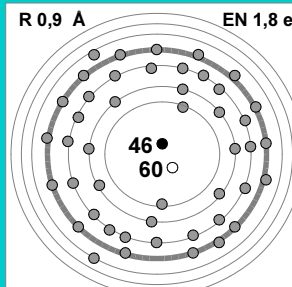
**46** **L**  
**Lurid**  
 Metall. Sòlid.  
 R 0,9 Å EN 1,8 eV  
  
 1s2 2s2 2p6 3s2 3p6 4s2 3d10 4p6 5s2 4d8  
**106**

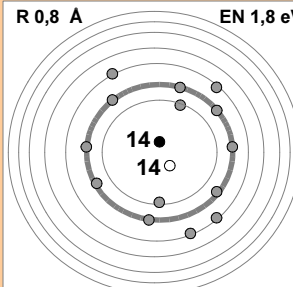
**14** **L**  
**Llull**  
 No Metall. Sòlid.  
 R 0,8 Å EN 1,8 eV  
  
 1s2 2s2 2p6 3s2 3p2  
**106**

Etapa 7

Equip 6

**39 De**  
**Deiviboui**  
 Metall. Sòlid.  
 R 1,2 A EN 1,2 eV  
  
 39●  
 51○  
 1s2 2s2 2p6 3s2 3p6 4s2 3d10  
 4p6 5s2 4d1  
**90**

**36 Me**  
**Mendel**  
 No Metall. Gas.  
 R 0,6 A EN -- eV  
  
 36●  
 48○  
**84**

**Pt**  
**Pasteur**  
 No Metall. Gas.  
 R 0,7 A EN -- eV  
  
 77●  
 108○  
 1s2 2s2 2p6 3s2 3p6 4s2 3d10  
 4p6 5s2 4d10 5p6  
**131**

**53 Ag**  
**Agusti**  
 No Metall. Sòlid.  
 R 0,8 A EN 2,1 eV  
  
 53●  
 74○  
 1s2 2s2 2p6 3s2 3p6 4s2 3d10  
 4p6 5s2 4d10 5p5  
**127**

**31 B**  
**Beker**  
 Metall. Sòlid.  
 R 0,8 A EN 1,7 eV  
  
 31●  
 39○  
 1s2 2s2 2p6 3s2 3p6 4s2 3d10  
 4p1  
**70**

**49 Cs**  
**Castre**  
 Metall. Sòlid.  
 R 1 A EN 1,6 eV  
  
 49●  
 66○  
 1s2 2s2 2p6 3s2 3p6 4s2 3d10  
 4p6 5s2 4d10 5p1  
**132**

Etapa 8

Equip 6

**23 Jo**  
**Jonlihuka**  
 Metall. Sòlid.  
 R 0,8 A EN 1,5 eV  
  
 23●  
 28○  
**51**

**30 Sv**  
**Stiviinvud**  
 Metall. Sòlid.  
 R 0,7 A EN 1,6 eV  
  
 30●  
 35○  
 1s2 2s2 2p6 3s2 3p6 4s2 3d10  
**65**

**28 E**  
**Elvispresli**  
 Metall. Sòlid.  
 R 0,7 A EN 1,8 eV  
  
 28●  
 31○  
 1s2 2s2 2p6 3s2 3p6 4s2 3d8  
**59**

**25 Ja**  
**Janisjopli**  
 Metall. Sòlid.  
 R 0,7 A EN 1,6 eV  
  
 25●  
 30○  
 1s2 2s2 2p6 3s2 3p6 4s2 3d5  
**55**

**Bo**  
**Bonó**  
 Metall. Sòlid.  
 R 0,7 A EN 1,8 eV  
  
 29●  
 34○  
 1s2 2s2 2p6 3s2 3p6 4s2 3d9  
**63**

Etapa 9

Equip 6

47 Mi

MicJagre

Metall. Sòlid.

R 1 A EN 1,9 eV

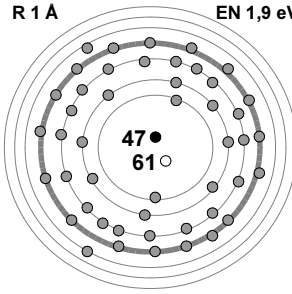

1s2 2s2 2p6 3s2 3p6 4s2 3d10  
4p6 5s2 4d9 108

48 T

Tinatarna

Metall. Sòlid.

R 1,1 A EN 1,7 eV

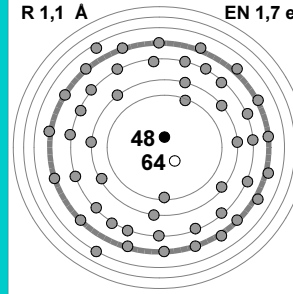

1s2 2s2 2p6 3s2 3p6 4s2 3d10  
4p6 5s2 4d10 112

42 Ku

Kurtcoben

Metall. Sòlid.

R 0,85 A EN 1,5 eV

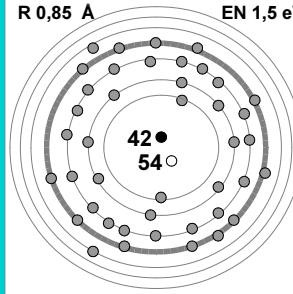

1s2 2s2 2p6 3s2 3p6 4s2 3d10  
4p6 5s2 4d4 93

26 N

Ninasimoni

Metall. Sòlid.

R 0,7 A EN 1,7 eV

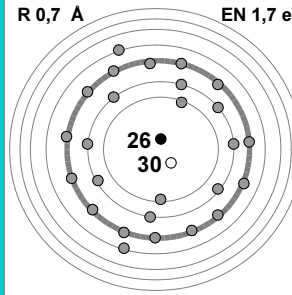

1s2 2s2 2p6 3s2 3p6 4s2 3d6  
56

27 Pr

Princi

Metall. Sòlid.

R 0,7 A EN 1,7 eV

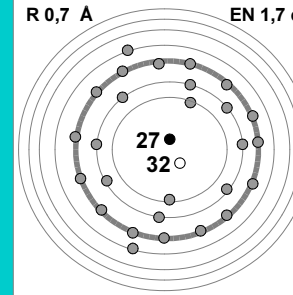

1s2 2s2 2p6 3s2 3p6 4s2 3d7  
59

44 Ji

Jimorisen

Metall. Sòlid.

R 0,8 A EN 1,9 eV

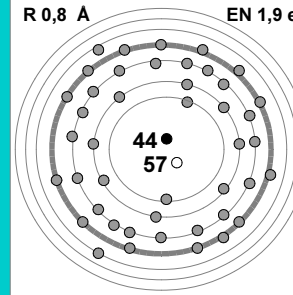

1s2 2s2 2p6 3s2 3p6 4s2 3d10  
4p6 5s2 4d6 101

Etapa 10

Equip 6

45 Pa

Pattismit

Metall. Sòlid.

R 0,81 A EN 1,9 eV

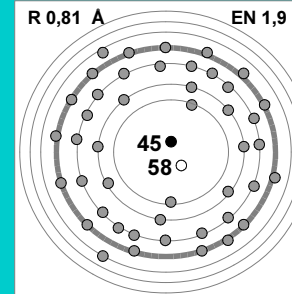

1s2 2s2 2p6 3s2 3p6 4s2 3d10  
4p6 5s2 4d7 103

40 Bi

Bibiquin

Metall. Sòlid.

R 1 A EN 1,3 eV

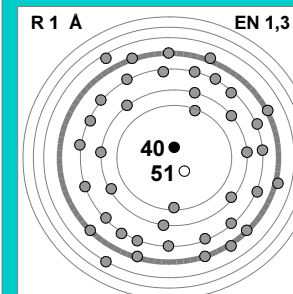

1s2 2s2 2p6 3s2 3p6 4s2 3d10  
4p6 5s2 4d2 91

46 L

Lurid

Metall. Sòlid.

R 0,9 A EN 1,8 eV

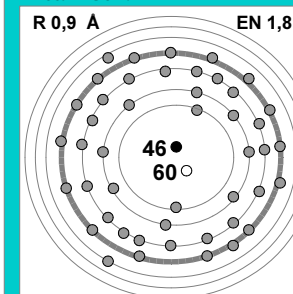

1s2 2s2 2p6 3s2 3p6 4s2 3d10  
4p6 5s2 4d8 106

41 Jc

Joucuca

Metall. Sòlid.

R 0,9 A EN 1,4 eV

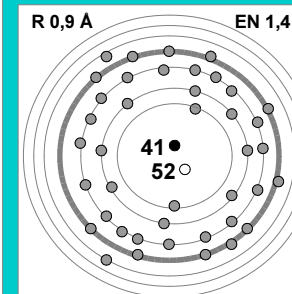

1s2 2s2 2p6 3s2 3p6 4s2 3d10  
4p6 5s2 4d3 93

43 Pt

Patsiclain

Metall. Sòlid.

R 0,8 A EN 1,7 eV

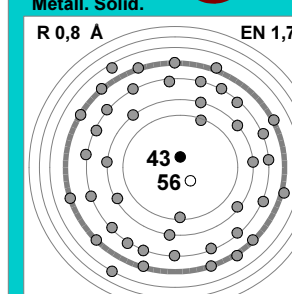

1s2 2s2 2p6 3s2 3p6 4s2 3d10  
4p6 5s2 4d5 99